



by

# JH INDUSTRIES, INC.

## Edge-of-Dock

### SEL Series

Copperloy offers both Mechanical and Hydraulic Edge-of-Dock Levelers available in 66", 72", 78" and 84" width's  
20,000 lb. and 30,000 lb. capacities

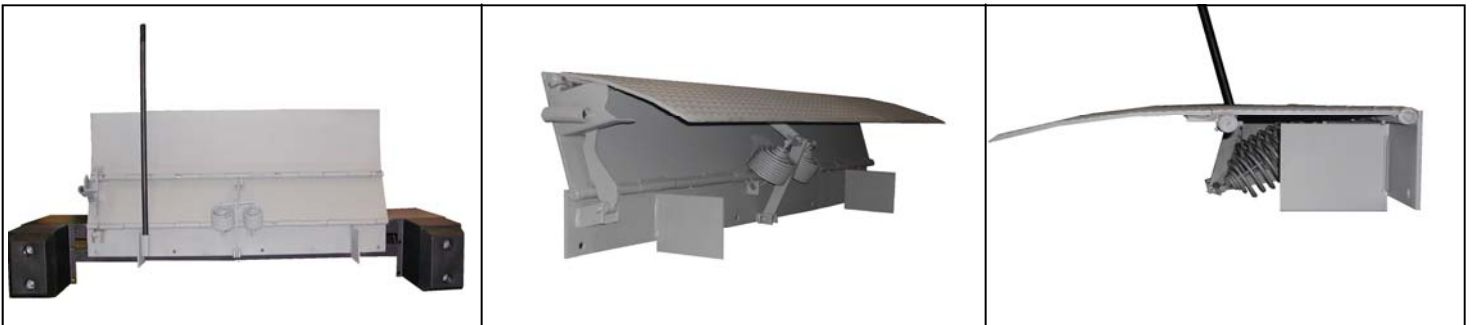

*Simply pull back the handle and the lip will mechanically lift over the dock height. Then, a slight forward push of the handle will position the lip onto the truck floor.*

### FEATURES AND BENEFITS:

**Our Edge-of-Dock Levelers** are smooth and easy to operate. Whether using the handle or the wall-mounted push button (on the hydraulic unit) your Edge-of-Dock extends fully to the height of the trailer bed for safe freight handling. **All the benefits of the mechanical system are also available in our hydraulic models.**

**To ensure product durability**, the Copperloy Edge of Dock has been designed and engineered using a three dimensional engineering software package.

**Quick, easy lifting and positioning:**

Our exclusive lift mechanism and spring assembly sets the board in place with one-quarter the effort needed to operate a conventional edge of dock.

**Push button operation on hydraulic models.**

**Ideal for retrofit:** The Copperloy Edge of Dock easily mounts to the face of almost any dock. Transition plates and approach ramps are also available.

**Safety:** All Copperloy Edge of Dock Levelers are equipped with a **safety maintenance strut** to secure the unit while performing routine maintenance.

**Low maintenance:** Maintenance is reduced to simple lubrication of hinges which come equipped with grease fittings.

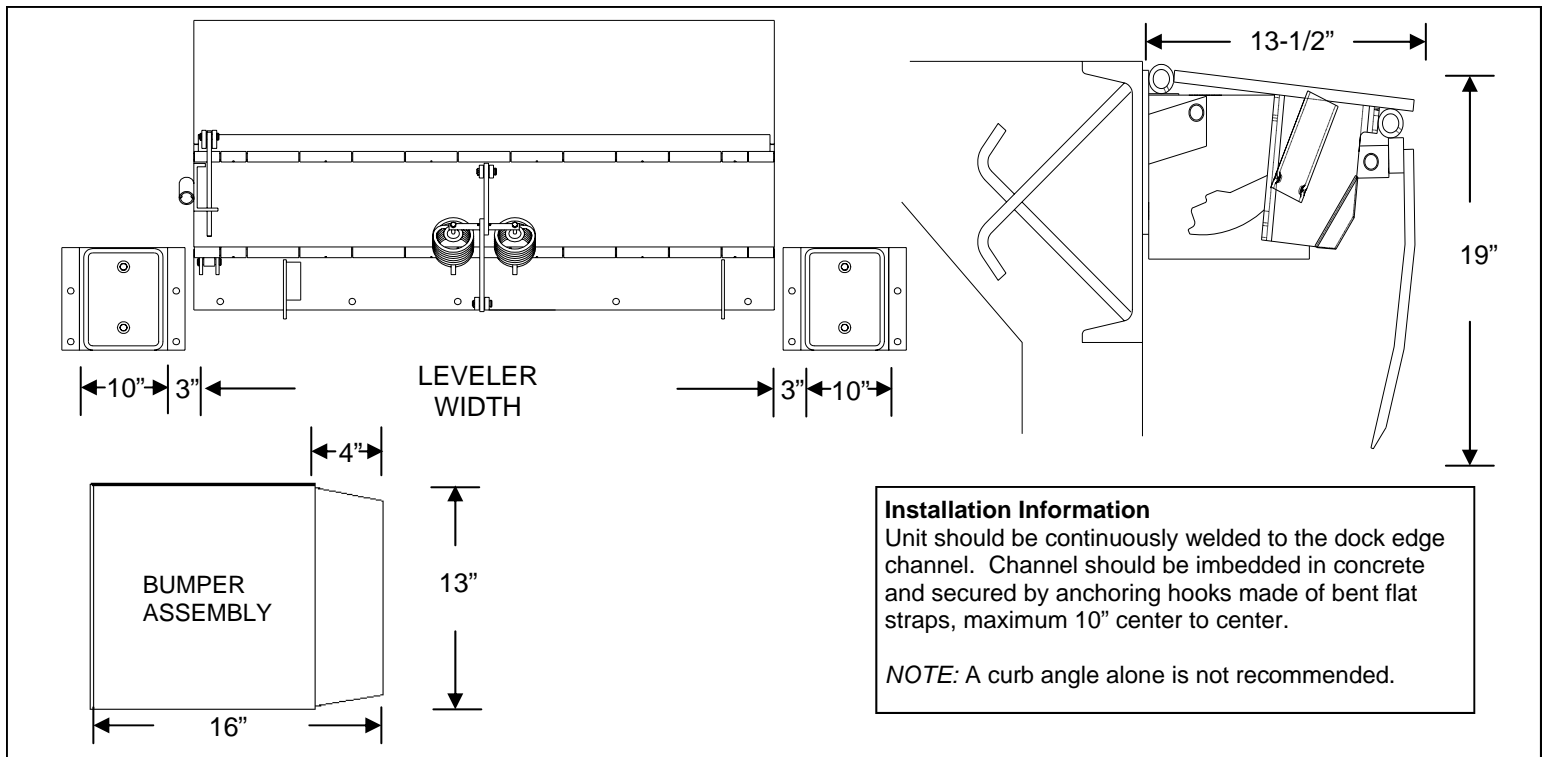

**SPECIFICATIONS:**

**Materials:** High strength low alloy (50,000 lb. Minimum Yield) tread plate, lip beveled for smooth transition.

**Projections:** Bumpers 16". Ramp 13 1/2" in stored position. Lip extends 12 1/2" beyond bumper.

**Bumpers:** 4" x 13" x 10" molded reinforced rubber mounted to steel box frame.  
 • Optional 4" x 12" x 13" bumper assembly

**Lift Assist:** Dual extension springs.

**Finish:** Unit is completely cleaned, deburred and painted gray.

**Service Range:** Capable of servicing trucks 5" above and 5" below the dock.

**Capacities:** 20,000 lb. and 30,000 lb.

**Widths:** 66", 72", 78", 84"

**Options: (Consult factory for more information)**

- Refer lip
- Reduced lip bend
- In-Board Handle Assembly
- Hydraulic Model— 115/230 VAC Single Phase

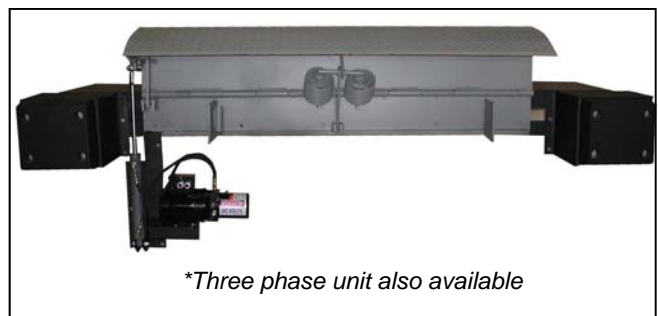

**CAM Model (12.5" Projection)**

<u>Capacity</u>	66" wide	72" wide	78" wide	84" wide
20,000 Lb.	SEL2066CG	SEL2072CG		
30,000 Lb.	SEL3066CG	SEL3072CG	SEL3078CG	SEL3084CG

**Refer Model (14" Projection)**

<u>Capacity</u>	66" wide	72" wide	78" wide	84" wide
20,000 Lb.	SEL2066CRG	SEL2072CRG		
30,000 Lb.	SEL3066CRG	SEL3072CRG	SEL3078CRG	SEL3084CRG